

The mobile MÜLLER lifting column

Ideal for transporting and lifting of your EURO pallets or IBC containers! Müller's mobile lifting column makes child's play of accurate positioning, such as over a tablet press. This electrically driven unit can cover even long distances on your production site effortlessly. Various models are available; from 500 kg to 1500 kg load capacity.

The unit can be equipped with a range of carrying arm and pickup systems – including one to suit your containers. And if you want to handle drums instead of containers, the unit can be supplied with an inverting gear. Heavy loads can therefore be handled and transported easily and ergonomically.

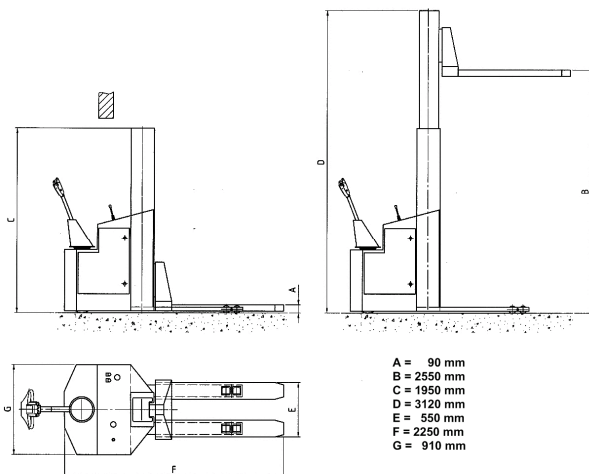

Details:

- For handling of Euro pallets or IBC containers
- GMP compliant, even the telescopic mast due to front completely covered
- Machine height 1950 mm – to pass standard door height
- Entire lifting height usable
- Lifting height max. 2550 mm
- Simple operation and accurate positioning
- Chassis with electric motor
- Lifting/lowering by hydraulic motor
- Highly stable
- Easy to maintain
- Entirely in stainless steel AISI 304
- Easy to clean thanks to smooth surfaces
- Load capacity up to 1500 kg
- CE marking
- upon request available with inverting gear for drums
- upon request available for ATEX Zone 1/21 or 2/22

We look forward to your inquiry.